

... GETS MORE OUT OF FRUITS



## **MOBILE JUICE PRODUCTION UNIT**

### SERIES KML 400 ECO

## ADVANTAGES

- The trailer is completely made of stainless steel and aluminium
- Heat-exchanger with automatic temperature regulation
- Heat-exchanger with automatic temperature regulation
- Pure juice without chemical additions  
Liquids can be bottled hot or cold
- Central floor drain for washing water

# MOBILE JUICE PRODUCTION UNIT

## SERIE KML 400 ECO

### The perfect introduction to mobile fruit processing

The trailer is a starter model and consists of a basic assembly for the perfect production of fruit juice. This version is especially suited for newcomers in the field of fruit processing. With this mobile juice production unit, the press comes to the fruit and not vice versa. This saves you unnecessary time and distances.



## WORKMANSHIP

The mobile Juice Production Unit KML 400 ECO is used for the processing of fruit juices on site. The fruit is loaded into the washing container, transported to the grinder, crushed and then conducted to the sieve belt press. The generated juice then flows from the press into a buffer tanks and is thereby filtered twice. The tank is placed on the ground next to the unit during the pressing process.





## EASY OPERATION

This unit offers nearly unlimited mobility, and is ready to use in a short time if relocated to a different site.

To start operation, you only require a water- and a power connection.

Due to the special construction of the filling valve, you can achieve a high filling accuracy and avoid delay yield.



Mobile washing, grinding and press unit

- Caption:** 1) Washing elevator KWEM 1000 with slanted conveyor and grinder  
 2) Single-belt press KEB 400 ECO with 3 press rolls and belt cleaning  
 3) Pasteurizer 500L/h oil with juice pump, efficient boiler and heat-exchanger  
 4) Bag in Box bottler KBF 1000 with stainless steel buffer tank



2

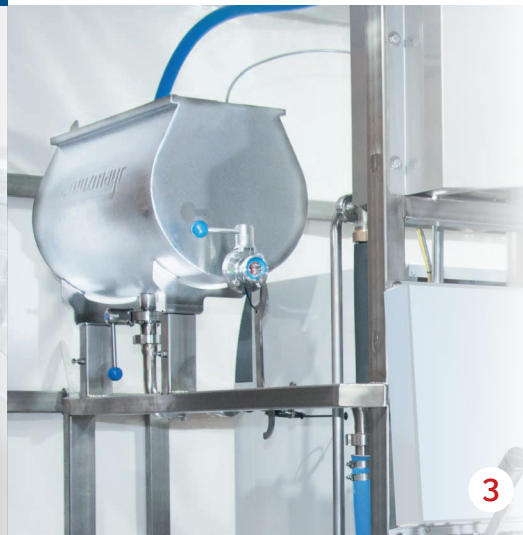

3



4

# MOBILE JUICE PRODUCTION UNIT KML 400 ECO

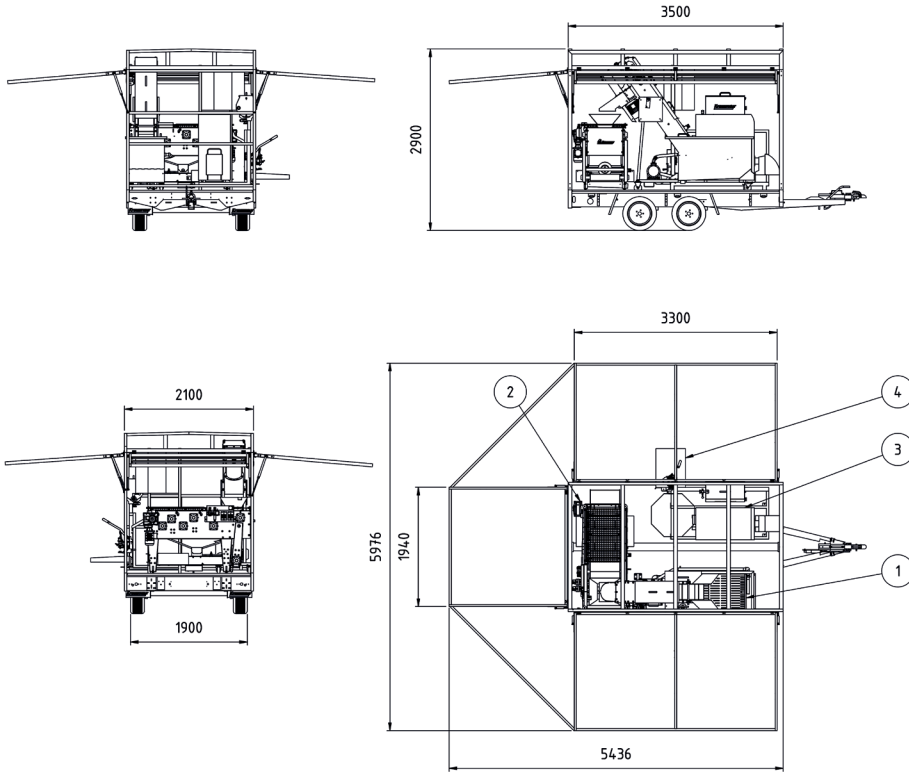

## ALL UNITS OF THIS ASSEMBLY

Position	Description	Washing and	Model	Energy	Capacity	Power supply
1	grinding unit		KWEM 1000	electric	2.000 kg/h	3,40 kW
2	Single belt press		KEB 400 ECO	elektric	700 kg/h	0,50 kW
3	Pasteurizer		PAS 500	heating oil	500 ltr/h	43,00 kW
4	BAGinBox filling machine		KBF 1000	elektric	max. 1.000 ltr/h*	0,10 kW

\*1) 650 ltr/h with 5 ltr Bags  
1.000 ltr/h with 10 ltr Bags

## OPTIONAL

Additional tank for more flexibility

Legs can be adjusted with a crank in order to reach an optimal level and more stability

Spare wheel

## OTHER INTERESTING PRODUCTS FOR PERFECT FRUIT PROCESSING



### MOBILE JUICE PRODUCTION UNIT

Fruit processing for everyone on site



### MOBILE UNIT ON SHUTTLE CONTAINER

The most flexible unit



### BELTPRESSES

Automatic, continous pressing of fruits



### BAGinBOX FILLING MACHINE

Quick and convenient BAGinBOX filling



### BOTTLE FILLING MACHINE

Manuall or automatic filling of bottles

## Kreuzmayr Maschinenbau GmbH



A-4702 Wallern / Trattnach  
Schallerbacher Straße 77

Tel: +43(0)7249/48817-0  
Fax: +43(0)7249/48817-10  
office@kreuzmayr.com  
www.kreuzmayr.com